

FLOATING BALL VALVE

CAST & FORGED

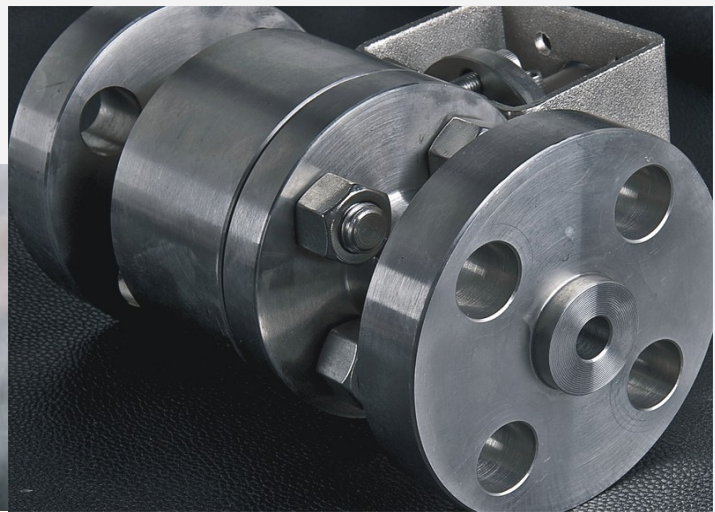

INTRODUCTION

E-FLOW is committed to provide the best quality and value in our products and services to meet every user's needs

E-FLOW OVERVIEW

E-FLOW was established on the year 2008 with the co-operation of Realtec Pte Ltd together with various reputable valve manufacturing company in Korea, Taiwan and China.

With the aim of becoming a global company trusted by worldwide customers, we form the partnership to bring our combined year of experience together in development of application-based and problem solving design specifications to provide solution with the best performance.

E-FLOW valves to provide superior products with the best technology together with the highest quality to meet every user's needs at the lowest cost.

Our vision is to provide the best quality and value in our products and services

MARKET SERVED

E-FLOW product provides flow control solutions to a wide range of market and has been widely used in:

- ⇒ Oil and Gas
- ⇒ Power Plant
- ⇒ Paper Making & Pulp
- ⇒ Petroleum & Petrochemical
- ⇒ Biopharmaceutical
- ⇒ Food & Beverage
- ⇒ Beer Beverage
- ⇒ Tobacco
- ⇒ Refined Sugar
- ⇒ Water Treatment Plant



DESIGN FEATURES

Body Construction

One- or two-piece bolted construction designed for maximum rigidity against pipeline forces. Bolted construction allows ease of service and on-site maintenance. User friendly design permits for easy and fast part replacement on field with minimum down time.

Completely Tight Shut-Off

Independent floating Inconel spring loaded seat rings are always in contact with the ball to provide an effective tight seal at low differential pressures.

Low Operating Torque that Requires Smaller Actuator

The ball turns on two special dry PTFE impregnated bushes that require low operating torques. These are maintenance free life even under the most severe service conditions. For size 6" and above, the stem is independent from the ball and therefore not affected by side thrust.

Antistatic Device

To meet the antistatic requirements of BS 5351, all the valves incorporate two stainless steel spring loaded plugs which ensure electrical continuity between ball and stem and between stem and valve body.

Seal System

Ball valves are designed with a multi-independent stem seal system with adjusting packing to provide an economical solution and control.

Fire Safe

The valves are tested to resist with very low losses to fire exposure, both outside and on-line. All valves are conform to API 607 latest edition and are tested and certified by independent inspectors. The problem of fluid loss has been resolved by using the primary seal plus secondary fire-proof expanded graphite seals on the stem, body and seat rings.

Blow Out Proof Stem

Positive anti-blow-out stem design on the complete product range prevents stem removal when valve is installed. This feature allows easy replacement of upper stem seals – double O-rings and expanded graphite – while the valve is installed (in closed position).

NACE MR-01-75 Compliance

All materials can be supplied to NACE MR-01-75 compliance. Compliance is ensured during the manufacturing process by strict inspection and material control.

High Flow Capacity

All valves design allows for high flow rate in liquid and gas regardless the quality of the media. Pigging and ensuring of high flow capacity are allowing for full port valves.

CAST STEEL TYPE

DESIGN & INSPECTION STANDARD

Design Standard	ASME B16.34 / BS5351 / API 6D
Face To Face	ASME B16.10
Flange Ends	ASME B16.5
Testing	API 598 / BS 6755
Fire Safe Test	API 607 / API 6FA

TYPE

Size	1/2" - 10" / DN 15—DN 250
ASME Class	150 & 300
Bore	Full & Reduced

PRESSURE / TEMPERATURE CURVE

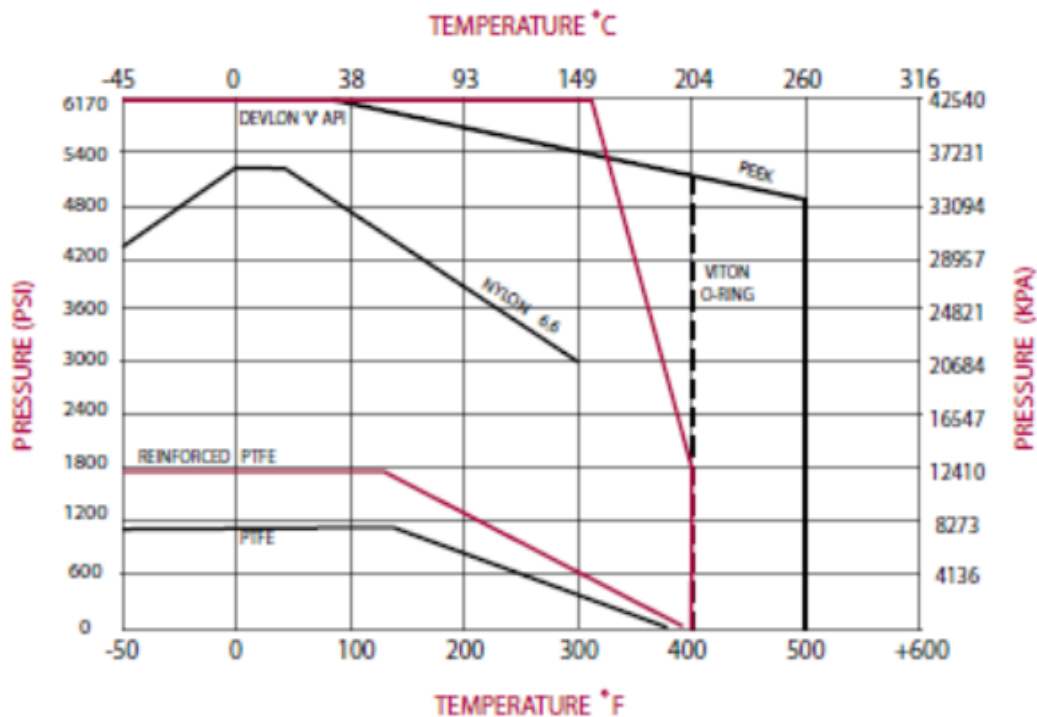

MATERIAL OF CONSTRUCTION

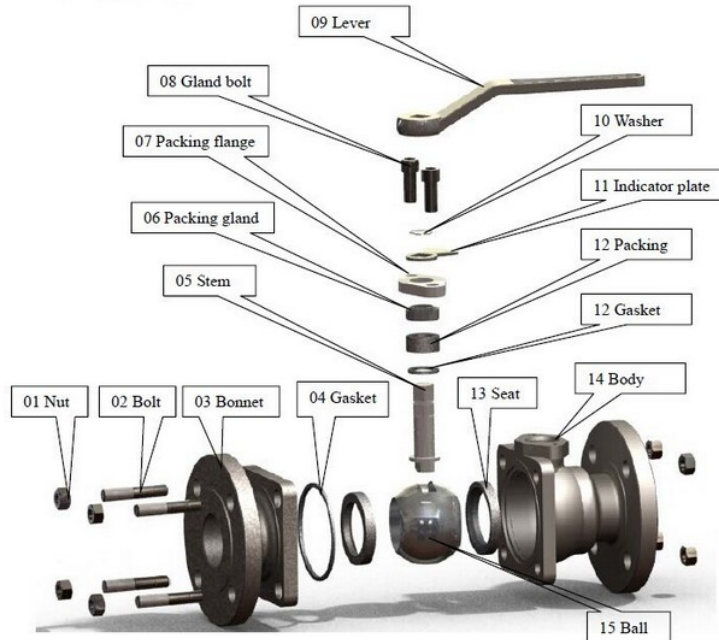

Description	Carbon Steel Body	Stainless Steel Body	Low Temperature Steel Body
Body	A216 WCB	A351 CF8M	A352 LCC
Adaptor	A216 WCB	A351 CF8M	A352 LCC
Ball	A105 / ENP	A182 F316	A182 F316
Seat	RPTFE	RPTFE	RPTFE
Stem	A182 F6a	A182 F316	A182 F316
Gland	A216 WCB	A351 CF8M	A352 LCC
Gasket	SS304 + Graphite	SS316 + Graphite	SS316 + Graphite
Thrust Washer	PTFE	PTFE	PTFE
Packing	PTFE / Graphite	PTFE / Graphite	PTFE / Graphite
Anti Static Device	Stainless Steel	Stainless Steel	Stainless Steel
Body Stud	A193 B7	A193 B8	A193 L7M
Body Nut	A194 2H	A194 8	A194 7M
Stop Plate	Carbon Steel	Stainless Steel	Stainless Steel
Retainer	Carbon Steel	Stainless Steel	Stainless Steel
Lever	Carbon Steel	Carbon Steel	Carbon Steel

FORGED STEEL TYPE

DESIGN & INSPECTION STANDARD

Design Standard	ASME B16.34 / BS5351 / API 6D
Face To Face	ASME B16.10
Flange Ends	ASME B16.5
Testing	API 598 / BS 6755
Fire Safe Test	API 607 / API 6FA

TYPE

Size	1/2" - 10" / DN 15—DN 250
ASME Class	150, 300, 600, 900, 1500 & 2500
Bore	Full & Reduced

PRESSURE / TEMPERATURE CURVE

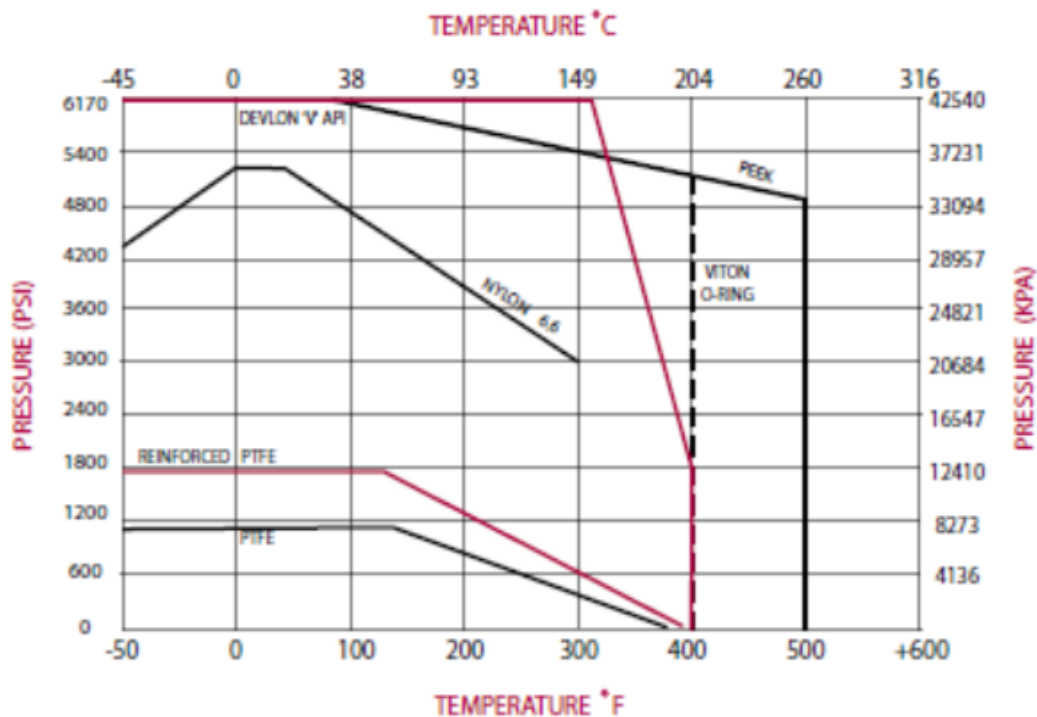

MATERIAL OF CONSTRUCTION

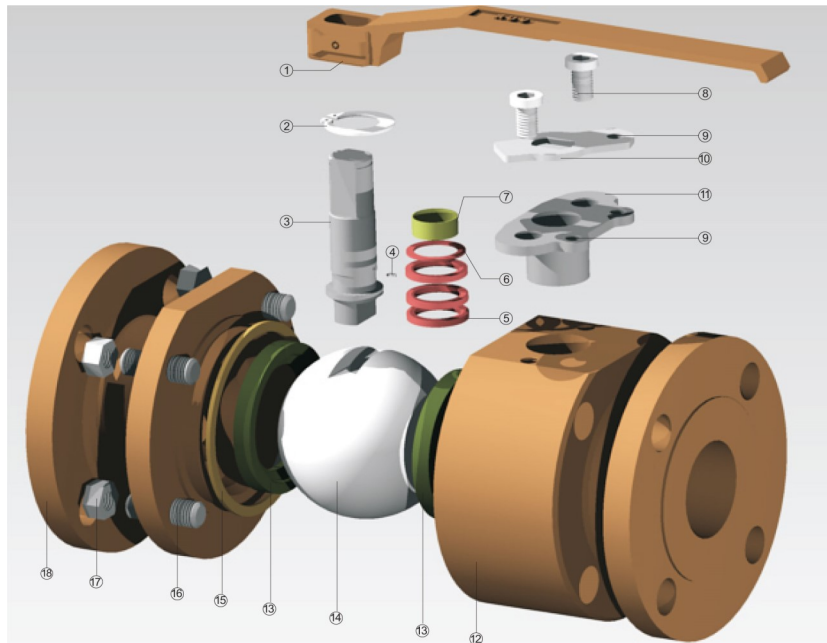

Description	Carbon Steel Body	Stainless Steel Body	Low Temperature Steel Body
Body	A105	A182 F316	A350 LF2
Adaptor	A105	A182 F316	A350 LF2
Ball	A105 / ENP	A182 F316	A182 F316
Seat	PTFE / Nylon	PTFE / Nylon	PTFE / Nylon
Stem	A182 F6a	A182 F316	A182 F316
Gland	A276 410	A182 F316	A182 F316
Gasket	SS304 + Graphite	SS316 + Graphite	SS316 + Graphite
Thrust Washer	PTFE	PTFE	PTFE
Packing	PTFE / Graphite	PTFE / Graphite	PTFE / Graphite
Anti Static Device	Stainless Steel	Stainless Steel	Stainless Steel
Body Stud	A193 B7	A193 B8	A193 L7M
Body Nut	A194 2H	A194 8	A194 7M
Stop Plate	Carbon Steel	Stainless Steel	Stainless Steel
Retainer	Carbon Steel	Stainless Steel	Stainless Steel
Lever	Carbon Steel	Carbon Steel	Carbon Steel